

Tire Roller / Tandem Roller 4ton Combined Roller

Tire Roller

Dimension

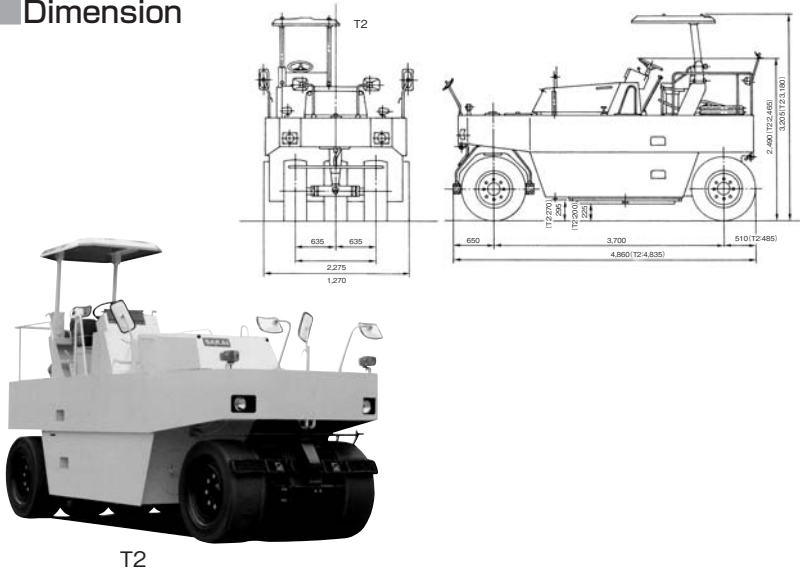

Specifications

Make	SAKAI	
Model	T2-1	
Weight	Gross weight (kg)	15,000
	Empty weight (kg)	9,200
Dimensions	Overall length (mm) A	5,020
	Overall width (mm) B	2,275
	Overall height (mm) C	2,905
	without auning (mm) D	2,210
	Wheel base (mm) E	3,850
	Ground clearance (mm) F	250
Roll Dimensions	Front roll (mm)	970×3pcs
	Rear roll (mm)	970×4pcs
Rolling width (mm)	2,275	
Minimum turning radius (m)	6.3	
Gradability (°)	22	
Travel speed (km/h)	0~19	
Engine	Rated output (ps/rpm)	99/2,100
	Piston displacement (cc)	4,329
Fuel tank capacity (ℓ)	100	
Sprinkler tank capacity (ℓ)	3,800	

Tandem Roller

Dimension

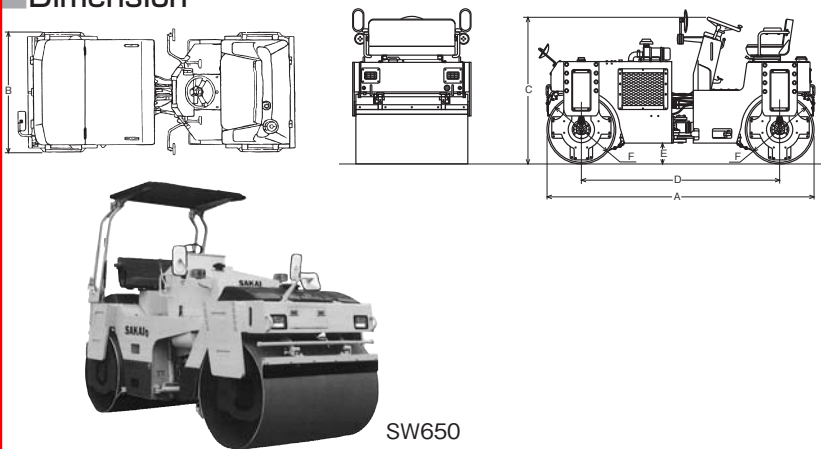

Specifications

Make	SAKAI	
Model	SW650	
Weight	Gross weight (kg)	7,100
	Overall length (mm) A	4,000
Dimensions	Overall width (mm) B	1,615
	Overall height (mm) C	2,780
	Wheel base (mm) D	2,900
	Ground clearance (mm) E	275
	Roll Dimensions F	1,070
	Rolling width (mm)	1,480
Minimum turning radius (m)	4.8	
Gradability (°)	19	
Travel speed (km/h)	3/11	
Engine	Rated output (ps/rpm)	55.9/2,050
	Fuel tank capacity (ℓ)	145
Sprinkler tank capacity (ℓ)	600	

Combined Roller

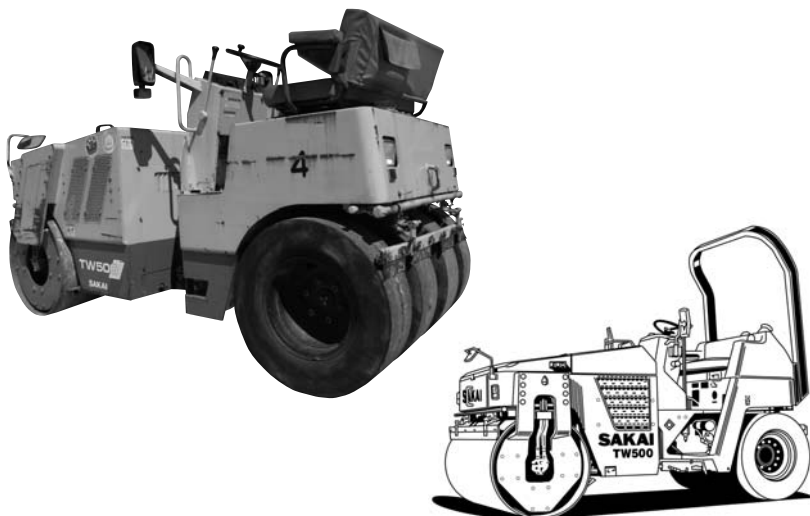

Specifications

Make	SAKAI	
Model	TW500	
Weight	Gross weight (kg)	3,550
	Empty weight (kg)	3,250
Dimensions	Overall length (mm) A	3,105
	Overall width (mm) B	1,390
	Overall height (mm) C	1,770
	without auning (mm) D	2,300
	Wheel base (mm) E	1,300
	Ground clearance (mm) F	250
Rolling width (mm)	555	
Minimum turning radius (m)	4.3	
Gradability (°)	22	
Travel speed (km/h)	0~13	
Engine	Rated output (ps/rpm)	30/2,500
	Piston displacement (cc)	1,499
Fuel tank capacity (ℓ)	47	
Sprinkler tank capacity (ℓ)	300	