

Nishio Tellastar Series (Engine)

Sky Tellastar (Self-Propelled Flood Light)



NT-15

■ Illuminated Area

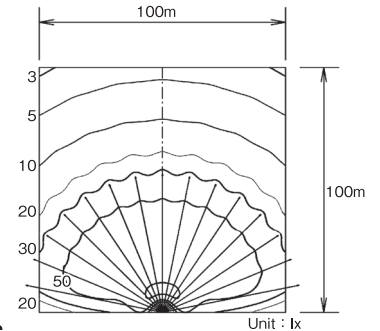

Specifications

Make	NISHIO	
Model	NT-15	
Bulb Capacity (watts × bulbs)	1,000 × 15	
Bulb Configuration	Metal Halide	
Bulb Output (Lumens × bulbs)	109,000 × 15	
Depression Angles	110°	
Max. Height (mm)	17,500	
Weight (kg)	9,232	
Dimension	Length (mm)	6,770
	Width (mm)	2,400
	Height (mm)	2,710
Turning Radius	360°	
Wheel Base (mm)	2,500	
Travel Speed (km/h)	2.0/4.0	
Fuel Tank Capacity (ℓ)	Diesel/70	

NEW Sky Tellastar (Self-Propelled LED Flood Light)



NTM-24 (270°)

■ Illuminated Area (270°)

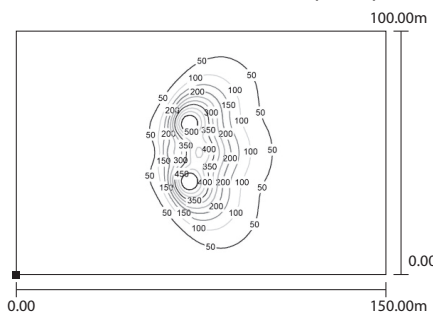

NTM-24 (180°)

■ Illuminated Area (180°)

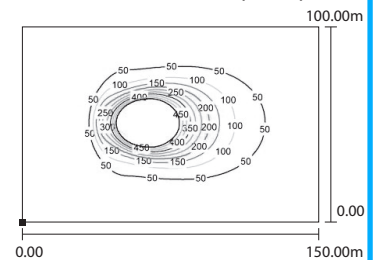

NTM-24 improved points from NT-15:

1. Turn on/off: Faster
2. Weight: Lighter
3. Moving: 4 Wheel Drives
4. Transportation: Cheaper
5. Fuel consumption: Lower



NTM-24 (360°)

■ Illuminated Area (360°)

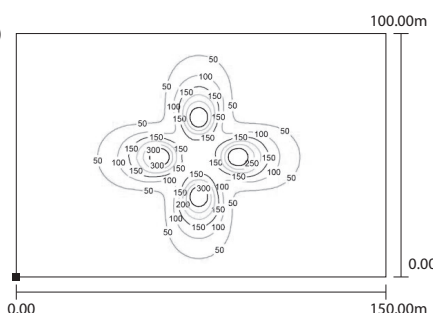

Specifications

Make	NISHIO	
Model	NTM-24	
Bulb Capacity (Watts × bulbs)	350x24	
Bulb Configuration	LED	
Bulb Output (Lumens × bulbs)	45,500 x 24	
Depression Angles	180°/ 270°/ 360°	
Max. Height (mm)	13,952	
Weight (kg)	6,883	
Dimension	Length (mm)	6,230
	Width (mm)	2,255
	Height (mm)	2,260
Turning Radius	360°	
Wheel Base (mm)	2,500	
Travel Speed (km/h)	8,0	
Fuel Tank Capacity (ℓ)	92	