

Walkie Stacker·Ride On Pallet Truck·Electric Pallet Truck·Hand Pallet

Walkie Stacker

■ Dimensions

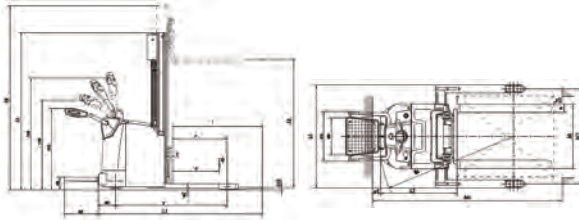

■ Specifications

Model		WSBSRE16-08PBVS
Max. Rated Capacity (kg)		1,600
Dimensions (mm)	Overall Length (L1)	2,050
	Overall Width (b1)	1,470
	Overall Height (h1)	2,195
	Fork Length	1,070
Min. Fork Height (mm) (h13)		50
Max. Lifting Height (h13 + h3)		2,750
Minimum Turning Radius (mm)		1,662 ⁽²⁾
Total Weight (kg)		1,432

⁽¹⁾When the masts are lowered.

⁽²⁾When the forks are lowered.

Ride On Pallet Truck

■ Dimensions

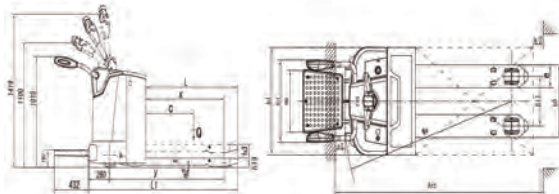

■ Specifications

Model		PTBXRE20-08PBVH (CBD20-AC2S)
Max. Rated Capacity (kg)		2,000
Dimensions (mm)	Overall Length (L1)	1,867
	Overall Width (b1)	800
	Overall Height	1,015 / 1,419
	Fork Length	1,150
Min. Fork Height (mm) (h13)		85
Max. Lifting Height (h13 + h3)		210
Minimum Turning Radius (mm)		1,627
Total Weight (kg)		726 ⁽²⁾

⁽¹⁾When the handle is raised to the minimum/ maximum height.

⁽²⁾When the forks are lowered.

Electric Pallet Truck

■ Dimensions

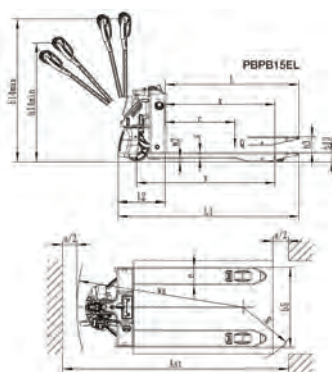

■ Specifications

Model		PBPB15EL	PTBXPE18-08LIYE (CBD18-JL3)
Max. Rated Capacity (kg)		1,500	1,800
Dimensions (mm)	Overall Length (L1)	1,540	1,603
	Overall Width (b5)	685	685
	Overall Height (h14)	750 / 1,190 ⁽¹⁾	740 / 1,160 ⁽¹⁾
	Fork Length	1,150	1,150
Min. Fork Height (mm) (h13)		80	200
Max. Lifting Height (h3+h13)		190	85
Minimum Turning Radius (mm)		1,330 ⁽²⁾	1,398 ⁽²⁾
Total Weight (kg)		120	142

⁽¹⁾When the handle is raised to the minimum/ maximum height.

⁽²⁾When the forks are lowered.

Hand Pallet



■ Specifications

Model	BF25	BF30M
Rated Capacity (kg)	2,500	3,000
Lifting Height (mm)	200	200
Overall Weight (two forks) (mm)	520	685
Wide (fork to fork) (mm)	370	370
Fork Lower (mm)	95	95
Tires	Non Making Tire	
Fork Length (mm)	1,200	1,200